

MOOER

STEREO LOOPER PEDAL

Owner's Manual

Content

Precautions-----	01
Features-----	02
Layout-----	03-06
Connections-----	07-09
Instructions-----	10-18
MOOERSTUDIOforLOOPERX2EditorSoftware-----	19-24
Specifications-----	25

PRECAUTIONS

Please read carefully before proceeding

Power Supply

Please connect the designated AC adapter to an AC outlet of the correct voltage. Please be sure to use only an AC adapter which supplies  9V DC, 3A, center negative. Unplug the AC power adapter when not in use or during electric storms. Please only use the original power supply included with your device.

Connections

Always turn off the power of this and all other equipment before connecting or disconnecting, this will help prevent malfunction and /or damage to other devices, Also make sure to disconnect all connection cables and the power cord before moving this unit.

Cleaning

Clean only with a soft, dry cloth. If necessary, slightly moisten the cloth. Do not use abrasive cleanser, cleaning alcohol, paint thinners, wax, solvents, cleaning fluids, or chemical-impregnated wiping cloths, interference with other electronic devices. Radios and televisions placed nearby may experience reception interference. Operate this unit at a suitable distance from radios and televisions.

Location

To avoid deformation, discoloration, or other serious damage, do not expose this unit to the following conditions.

- Direct sunlight
- Magnetic fields
- Excessive dusty or dirty location
- Heat sources
- Extreme temperature or humidity
- High humidity or moisture
- Strong vibrations or shocks

FCC certification

This device complies with Part 15 of the FCC Rules. Operation is subject to the following two conditions:

- This device may not cause harmful interference.
- This device must accept any interference received, including interference that may cause undesired operation.

Features

- Dual-footswitch stereo looper pedal
- Up to 77 save slots for a total of 300 minutes record time
- Auto Record function
- Fade Out function allows tracks to fade out naturally after playing stops
- Saving options are based on the structure of songs, allowing quick recording and playback anywhere
- Two footswitch modes allow players to switch between 7 different tracks while playing
- Compatible with external footswitch controller
- Specialized editor software for import/export of audio tracks and updating firmware

Layout

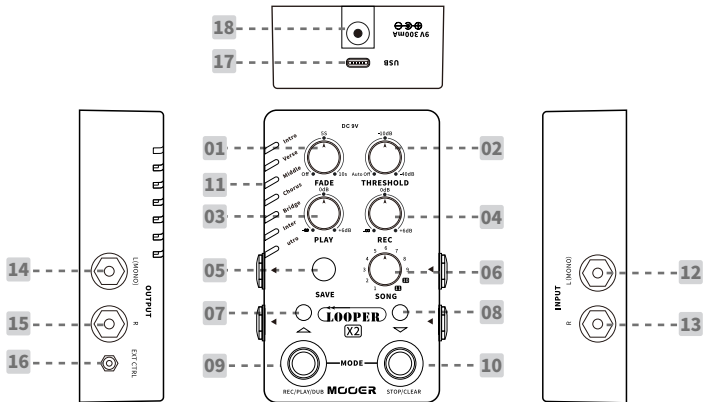

1、FADE:

FADE OUT time control. Rotate to adjust the fade out time. Rotate to 7 o'clock to turn off the fadeout function. The fade out time duration can be set to up to 10 seconds.

2、THRESHOLD:

Adjust the sensitivity of the AUTO REC function. Rotate to 7 o'clock to turn off the auto recording function. It is recommended to adjust it according to your playing preferences.

3、PLAY:

Looper playback volume level control, Rotate to 12 o'clock and the playback volume and thereal-time playing volume will be the same. It supports up to +6dB volume level boost.

4、REC:

Looper recording volume level control. Rotate to 12 o'clock and the playback volume and thereal-time playing volume will be the same. It supports up to +6dB volume level boost.

5、SAVE:

Press to go through preset slots 1-7. Press and hold to save currently recorded tracks.

6、SONG:

LOOPER X2 has 11 song banks. Each bank has 7 save slots (corresponding to the 7 LED indicators) Rotate to cycle through the 11 banks.

Notes: In banks 1-9, the maximum recording time of each slot is 2.5 minutes. In banks 10 and 11.the maximum recording time of each slot is 10 minutes.

7&8, Footswitch LED:

Indicates the running status of the looper

9, Left Footswitch:

In normal mode, you can press this footswitch for looper control, REC/PLAY/DUB/CLEAR/UNDOREDO/CANCEL. In preset select mode, press it to scroll up in the current song bank.

10, Right Footswitch:

In the normal mode, you can press the right footswitch to STOP/CLEAR the looper. In presetselect mode, press it to scroll down in the current song bank.

11, Preset LED indicator:

Chromatic preset slot LED indicators. GREEN indicates currently selected slot. OFF for empty slot. PURPLE for slot with recorded tracks.

12, INPUT L(Mono):

1/4" mono (TS) audio jack, please use it for mono setup (It is also the left channel of the stereo setup).

13, INPUT R:

1/4" mono (TS) audio jack, it is also the right channel of stereo setup.

14, OUTPUT R(Mono):

1/4" mono (TS) audio jack, please use it for mono setup (It is also the left channel of the stereo setup).

15. OUTPUT R:

1/4" mono (TS) audio jack, it is also the right channel of stereo setup.

16. EXT CTRL:

1/8" TRS jack, for connecting to external treble footswitch pedal (Need to purchase separately)

17. TYPE-C:

For connecting to computer for data transferring, firmware update.

18. DC IN:

Connect to 9V and at least 300mA current draw, center negative power supply. Original powersupply is recommended, Isolated power supply is recommended to avoid unexpected noise caused by power supply sharing.

Connections

Mono Pre-Looper

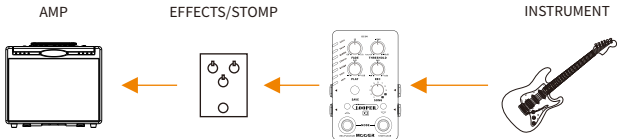

In this setup, the mono signal from the instrument is recorded directly, without any effects.

Mono Post-Looper

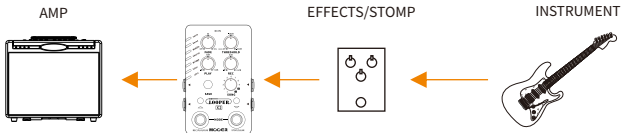

In this setup, the mono signal processed by the effects is recorded.

Stereo Pre-Looper

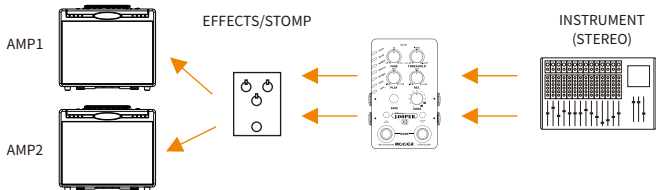

In this setup, the stereo signal from the instrument is recorded directly, without any effects.

Stereo Post-Looper

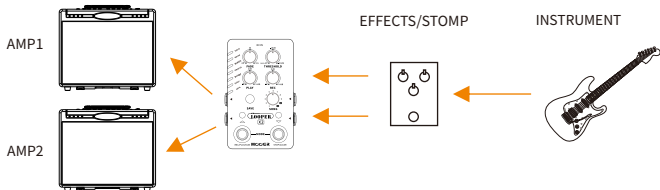

In this setup, the stereo signal processed by the effects is recorded.

Notes: The left output signal is from the left input; the right output signal is from the right input, Please ensure the connection is set up properly. (See the diagram below.)

AMP

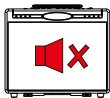

ROUT

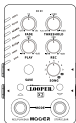

INSTRUMENT



L IN

AMP

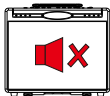

LOUT

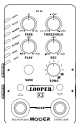

INSTRUMENT



R IN

Instructions

1. Start

*Plug in the power supply and set up your instruments, effects, and amplifier properly.

*Rotate the SONG knob to select an audio file, Press SAVE to select a slot in which to record.*tis recommended to set the PLAY and REC params both to 12 o'clock, to balance the volume of real-time playing, playback, and recording. You can adjust the volume level of the recording or playback by rotating PLAY Or REC.

*Rotate FADE and THRESHOLD to the far left to turn off FADE OUT and AUTO REC function. Now your Loop X2 is set up successfully. After becoming familiar with it, you can begin to set up more complicated functions later.

2. Basic Looper Operation

REC-PLAY-DUB:



STOP:

During REC/PLAY/DUB, press right footswitch to STOP, then press the left footswitch to continue REC/PLAY/DUB

RCE

PLAY

DUB



Press

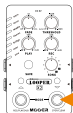

Press

STOP

PLAY

UNDO/REDO:

When there are more than 2 layers of tracks recorded, press and hold the left footswitch to UNDO the most-recorded layer. Before you record a new layer, you can press and hold the left footswitch again to REDO and the last layer will be recalled.

Press and hold



PLAY

UNDO

Press and hold



PLAY

REDO

PLAY



The last layer will be deleted.



Recall the last layer.

CANCEL:

if you make a mistake during DUB recording, you can cancel and delete current layer directly. Press and hold left footswitch to cancel, it is different from UNDO. canceled layer cannot be restored, and you can only cancel a layer during DUB.

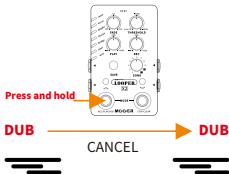

Delete the wrong layer and get back to DUB

DELETE:

Delete the recorded tracks which have not been stored yet, or delete the import audio file in current slot.



CLEAR:

Clear all the data (Including the saved recorded track and import audio file) in current slot.

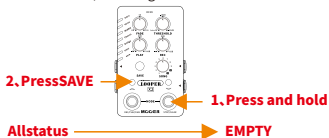

SAVE:

After recording is complete, press and hold SAVE to save the recorded track, Any unsaved tracks will be lost after power is off. Tracks exported from a computer will be stored into the device automatically without the need to perform the save operation.

FADE:

Rotate FADE to turn on the fade out function, When the fade out function is on, the current track will last for a while and then fade out naturally if you switch it off or switch to another track.

LOOPER X2 supports up to 10 seconds of fade out time. Rotate FADE to the far left to turn off the fade out function, When fade out is off, the track will switch immediately when powering off or switching to another track.



AUTO REC:

The AUTO REC can help to start recording automatically when an input signal is detected. You need to set up the threshold value of the AUTO REC and when the input signal is higher than the set value, the recording will start automatically.



Before using this function, please adjust the THRESHOLD to a proper value, select an empty slot, and press the left footswitch. The LED indicator of the left footswitch will start to blink in RED for standby. When any signal over the threshold value is detected, recording will start automatically.

Rotate THRESHOLD to the far-left position to turn off the AUTO REC function and you can start recording manually by pressing the left footswitch. The higher threshold value you set, the more difficult it is to activate the AUTO REC function.

Notes:

A. Before the actual recording, it is recommended to try for several times by adjusting the THRESHOLD, so that you can get a proper value in the actual recording.

B. What is the proper value of THRESHOLD? A value that can allow you to activate the AUTO REC via normal playing, and it cannot be affected by any other unexpected noise.

C. It is recommended to set up the THRESHOLD every time you switch to another instrument, as different instruments have different output signal level.

D. AUTO REC function is for recording the first layer only and cannot work with PLAY/DUB

Footswitch:

LOOPER X2 allows you to save audio files in slots and banks for use. Suitable for marking your creative sparks or recording different parts of your songs. You can switch between different tracks seamlessly while playing

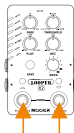

Press 2 footswitches

During playback, press the two footswitches simultaneously to enter the saving slot switching mode, both footswitch LEDs will blink in RED. Now you can scroll through the saving slots via left/right footswitch, left footswitch for scrolling up while right footswitch for scrolling down. The footswitch mode will be back to normal mode after being idle for 3 seconds: or you can press two footswitches simultaneously again to switch footswitch mode.

Notes:

Looper playback will switch to the next slot and begin playing automatically and seamlessly after the playback of the current track is complete. If the next slot is empty, then after the playback of the current track has finished, the looper will switch to the next slot and start recording.

External Footswitch:

The LOOPER X2 supports an external footswitch pedal control (purchased separately). The external footswitch connects to LOOPER X2 via TRS cable by the 1/8" EXT CTRL jack.



You can use the external footswitches to scroll up/down through save slots, UNDO/REDO/CANCEL etc.



Scroll up

Scroll down

UNDO/REDO/CANCEL

(External footswitch functions)

Notes:
It is recommended to use the TC Helicon SWITCH 3 or DIGITECH FS3X, or any treble footswitch pedal that works with binary coding.

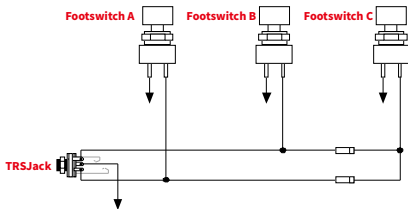

(Schematic Diagram)

Factory Reset:

Power Off the LOOPERX2, then press and hold SAVE button, Then power on the unit to reset it to factory settings. All data will be cleared after factory reset.

Firmware Up date(Enter update mode manually):

You can connect LOOPERX2 to a computer with the editor software installed to update the firmware. Connect the unit to a computer and select firmware update in the software, the unit will then be booted to update mode. The instructions below are for booting to update mode manually:

- Power Off the LOOPER X2 then press and hold both footswitches
- Power On the LOOPER X2
- The 1-7 LED indicators will blink chromatically to indicate booting to update mode
- Connect to a computer via USB cable
- Open the editor software and the update window will pop up
- Click on START to begin the update. Do not stop or power off your LooperX2 or your computer while the firmware is being updated. The update should only take a few minutes.

MOOER STUDIO for LOOPER X2 Editor Software

MOOER STUDIO for LOOPER X2 is the specialized editor software. Users can manage audiofiles and presets as well as perform firmware update via the software.

Please enter www.moeraudio.com-> SUPPORT-> DOWNLOAD for software downloads

System Requirements:

Win: Windows 10 or higher

Mac: Mac OS 10.15 or higher

Connection:

- 1.Connect LOOPER X2 to a computer via the USB cable in the package
- 2.Power on the unit
- 3.Open the editor software and click the CONNECT button at the top
- 4.CONNECTED will be displayed.

Software Interface

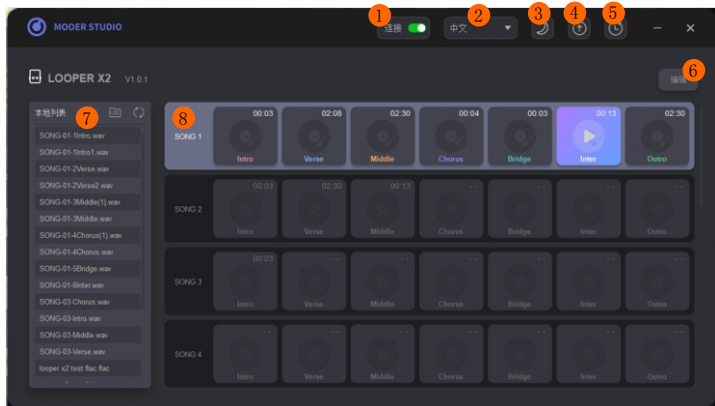

1. Connection Switch: Click to connect or disconnect to LOOPER X2.

2. Language: Click to select between Chinese and English.

3. Theme: Click to select between dark mode and light mode.

4. Update: Click to update the editor software or firmware update.

5. Factory Reset: Click to reset to factory settings.

6. Editing: Activate for multi-selection function, you can select and manage multiple files at same time.

7. Local List: The audio files in the computer. You can drag the file from computer to the

LOOPER X2 directly; or you can drag the file from LOOPER X2 to computer area.

8. Device List: It is listed by song banks. Rotate the mouse wheel, or drag the sliding block on the right side to go through the save slots.

Audio Preview:

The footswitch and button of LOOPER X2 will not work while connecting to computer for editing.

It is recommended to go through the audio file via editor software directly. The slot with the audio file will display the duration of the track. “..” will be displayed in the empty slot.

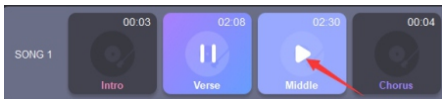

Click to select a slot with audio file, click on the arrow icon to play the track.

Import/ExportAudioFile:

Import single file:

Method 1: Right-click on the slot you wish to select and click on IMPORTSelect a file in the pop-up window forimporting.

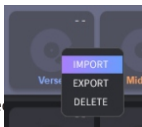

Method 2: Select a file from the Local Area and drag it to a slot in Device Area to import it.

Import multi-file:

Click on the EDIT button



into. Click on the IMPORT icon and select files you wish to import in the pop-up window andconfirm. Those files will be imported to the slots you just selected.

SELECT ALL Import Export Delete Complete

<input checked="" type="checkbox"/>	<input checked="" type="checkbox"/> 00:03	<input checked="" type="checkbox"/> 02:08	<input checked="" type="checkbox"/> 02:30	<input checked="" type="checkbox"/> 00:04	<input checked="" type="checkbox"/> 00:03	<input checked="" type="checkbox"/> 00:13	<input checked="" type="checkbox"/> 02:30
SONG 1	Intro	Verse	Middle	Chorus	Bridge	Inter	Outro
<input type="checkbox"/>	<input type="checkbox"/> 00:03	<input checked="" type="checkbox"/> 02:30	<input type="checkbox"/> 00:13	<input checked="" type="checkbox"/> --	<input type="checkbox"/> --	<input checked="" type="checkbox"/> --	<input type="checkbox"/> --
SONG 2	Intro	Verse	Middle	Chorus	Bridge	Inter	Outro
<input type="checkbox"/>	<input type="checkbox"/> 00:03	<input checked="" type="checkbox"/> --	<input checked="" type="checkbox"/> --	<input checked="" type="checkbox"/> --	<input type="checkbox"/> --	<input type="checkbox"/> --	<input type="checkbox"/> --
SONG 3	Intro	Verse	Middle	Chorus	Bridge	Inter	Outro
<input type="checkbox"/>	<input type="checkbox"/> --	<input type="checkbox"/> --	<input type="checkbox"/> --	<input type="checkbox"/> --	<input checked="" type="checkbox"/> --	<input checked="" type="checkbox"/> --	<input checked="" type="checkbox"/> --
SONG 4	Intro	Verse	Middle	Chorus	Bridge	Inter	Outro

Export single file:

Method 1: Right-click on the slot you wish to export and select EXPORT.

The file will be exported to the Local Area folder.

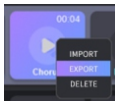

Method 2: Drag the file from the slot to the Local Area to export it to computer.

Export multi-file:

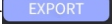
Click on the EDIT button  in the right side, then select the slots you wish to export and click on EXPORT icon to export.

Notes: The loading time of import/export is according to the size of the audio file, It will take a longer time if you import/export multiple files. Please wait until it finishes.

Import audiofile format:MP3/WAV/FLAC/APE

Export audiofile format:WAV

Sample rate/sample depth: No limitation (Editor software will transfer file to 44.1kHz/24bit automatically).

Duration: 1-9 song banks are 2.5 minutes; 10-11 song banks are 10 minutes.

Specifications

Input: 2*1/4" mono audio input jack (impedance value 1Mohm)

Output: 2*1/4" mono audio output jack (impedance value 510ohm)

Num. of saving slot: 77

Recording capacity: 300 minutes (stereo)

Sample rate/sample depth: 44.1kHz/24bit

Import audio file format: MP3/WAV/FLAC/APE

Export audio file format: WAV

Power requirements: 9V 300mA, center negative
(Original power supply is recommended, to avoid unexpected noise)

Dimension: 75mm(D)*115mm(W)* 33mm(H)

Accessories: Power supply, USB-C to USB-A cable, QuickGuide, LOGO Sticker

MOOER
www.moeraudio.com

SHENZHENMOOERAUDIOCO.LTD
6F,UnitD,JinghangBuilding,Liuxian3rdRoad,
Bao'an71District,Shenzhen,China.518133
MadeinChina